



0230-0211rF

PO BOX 4394
SANTA ROSA, CA
95402 USA

P (707) 525-9941
F (707) 575-7046
EMGPICKUPS.COM

INSTALLATION INFORMATION EMG MODELS: TB-HZ PICKUP

SPECIFICATIONS:

Logo Color
Magnet Type *
Inductance (Henries) (1)
DC Resistance (kOhm)
Resonant Frequency (KHz) (2)
Resonant Frequency (KHz) (3)
Impedance at Resonance (kOhm) (2)

MODEL:

TB-HZ
Silver
C/S
2.65
8.0
2.85
4.90
47.50

*Note: Magnet Type: C/S (Ceramic/Steel)

- (1) Wired in Series
- (2) Loaded with 500K Volume and Tone with a 20' (6M) Cable
- (3) Loaded with 1 MegOhm / 47pf

MAXIMUM RECOMMENDED STRING WIDTH 2.50"

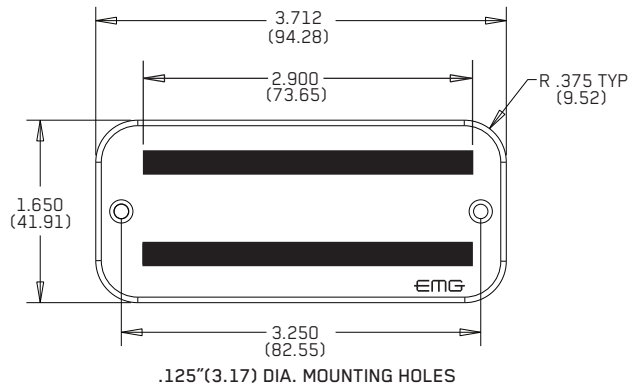

EMG-HZ WIRING

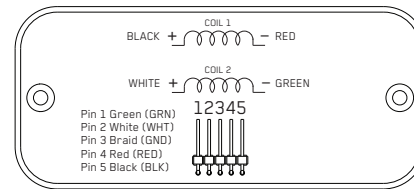

INCLUDED WITH THE PICKUP:

1 VOLUME CONTROL (250K)

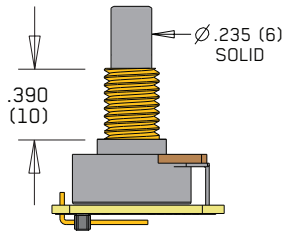

1 TONE CONTROL (250K)

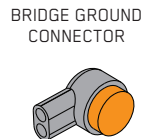
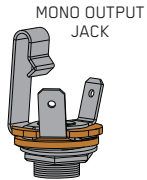
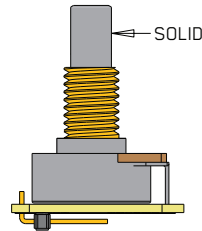

ADJUSTMENT SCREWS (2)

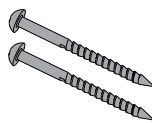

PICKUP CABLE 15" (30cm)



2 CONNECT CABLES 5.5" (14cm)



OUTPUT CABLE 6" (15cm)



BRIDGE GROUND WIRE 6" (15cm)



INSTALLATION NOTES:

The connector system allows an easy method of interchanging pickups. The 5-Wire Cable and wire legend are compatible with all other EMG-HZ Pickups, so any EMG-HZ Passive Pickup can be installed with any other EMG-HZ Pickup. The 5-Wire cable allows for Series/Parallel switching (see our solderless Series/Parallel Push Pull Pot) or coil-splitting for certain hardwire setups

See our website for more information: emgpickups.com.

SPECIAL NOTE: The Red Wire of the HZ Pickup Cable is NOT for battery power, it is a coil wire.

WARRANTY

All EMG Pickups and accessories are warranted for a period of two years. This warranty does not cover failure due to improper installation, abuse or damage. If upon examination the pickup is determined to be defective, a replacement will be made. Warranty replacement products are covered by this same warranty. This warranty covers only those pickups and accessories sold by authorized EMG Dealers. This warranty is not transferable.

Installation Instructions:

EMG Models: TB-HZ

General Notes:

Diagram #1 shows the installation of the Pickup Cable. Be sure to install it with the terminals as shown in the diagram.

Diagram #2 shows the Pickup cable itself. The cable is pre-wired as shown for "Series" wiring typical of Humbucking Pickups. If you wish to reverse the phase of the signal refer to Diagram #3. Send the Red wire to ground with the Shield and use the Green wire for output. In both cases the Black and White wires are hooked together and covered with an insulator.

Diagram #1

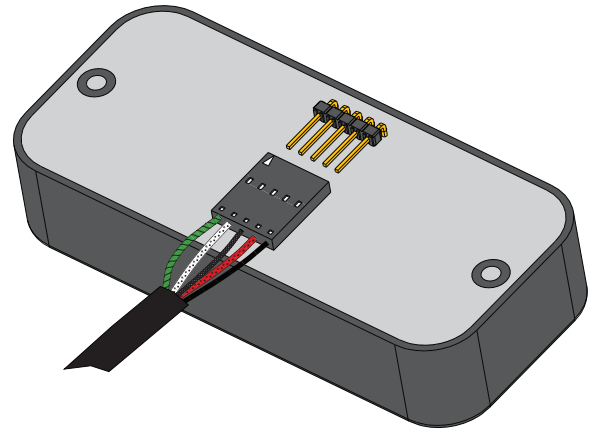

Diagram #2



**Diagram #3
(Reverse Phase)**



Common Wiring Diagrams:

Included in this data sheet are the most common wiring diagrams. The first diagram features wiring for a single pickup, while the rest are for guitars with 2 Pickups and 2 styles of selection switch.

Diagram #4

One Pickup
One Volume
One Tone

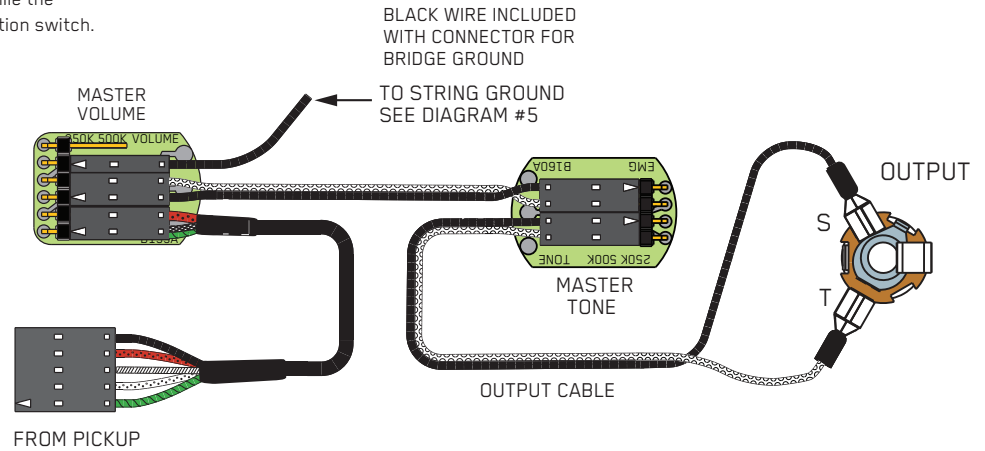

Attaching the bridge ground wire

6) Refer to Diagram #5.

As mentioned on page 1, it is common to "ground" (earth) the strings on guitars that have passive pickups. Included with the system is a black wire with a single black connector attached. Also included is an IDC connector for connecting the two wires together. Insert the bridge ground wire, and the connector wire into the IDC connector, crimp the connector with a pair of pliers until it snaps and this will connect the two wires. You don't need to strip the insulation from the wires. Push the black connector onto terminal 2 (GND) of the volume control as shown in the diagram. This will ground the strings to the system.

Diagram #5

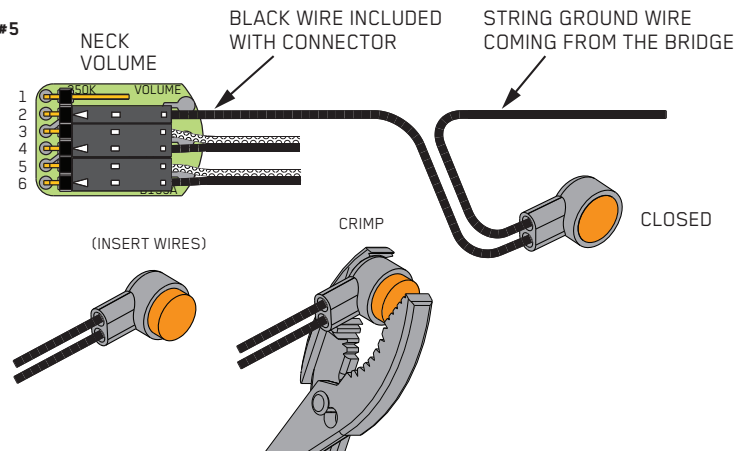

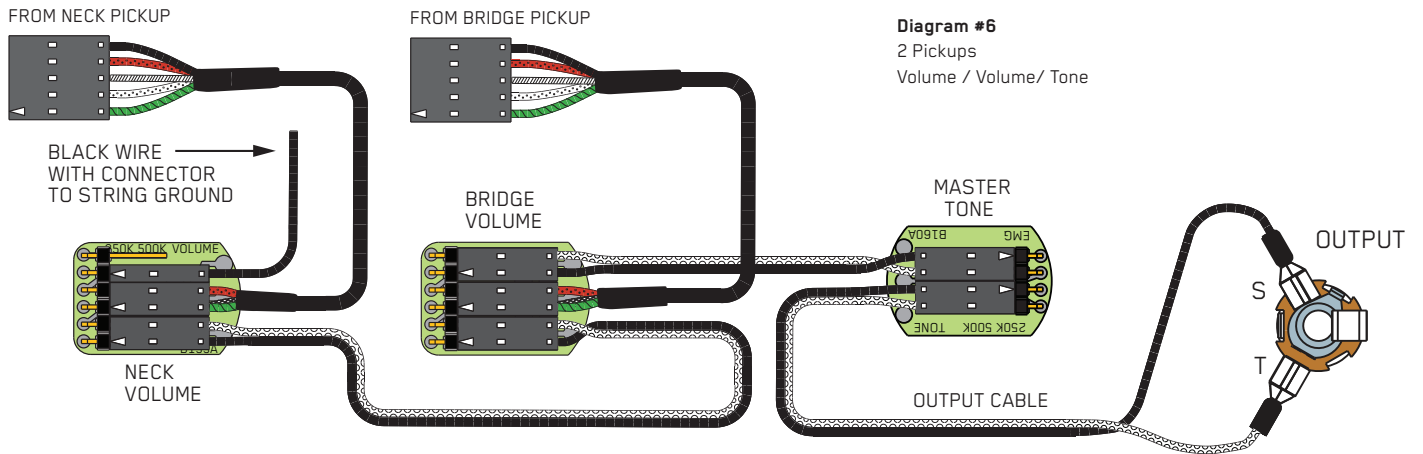

If your instrument has a selection switch:

Shown below is the EMG B245 Pickup Buss which is used for instruments that have 2 pickups and a 3 position selection switch. If you have a selection switch and want your installation to remain solderless, you'll need a B245 Buss. Either send an e-mail to: sales@emgpickups.com or call: 800 821-1446 to get the buss.

- 1) Install the Pickups and route the Pickup cables to the control cavity. If the cables are too long, wind up the excess and keep it under the pickup.
- 2) Mount the Volume and Tone controls into the body. Plug both Pickup cables into the Pickup Buss (BLACK Shroud) as shown, Refer to **Diagram #7**
Bridge Pickup to **BR IN**
Neck Pickup to **NK IN**

******Tips and Tricks******

Start your installation by:

- 1) Remove the strings
- 2) Remove any existing Pickups and controls (remember the order and function of each control)
- 3) Determine a good spot for the Pickup Buss and make sure the cable or wires from the selection switch will reach the Pickup Buss,
- 4) Install the EMG Volume and Tone Controls and tighten them in.
- 5) Then install the pickups keeping any excess cable under the pickup rather than in the control cavity.

Diagram #7
2 Pickups
Toggle Style Select Switch
Master Volume / Master Tone

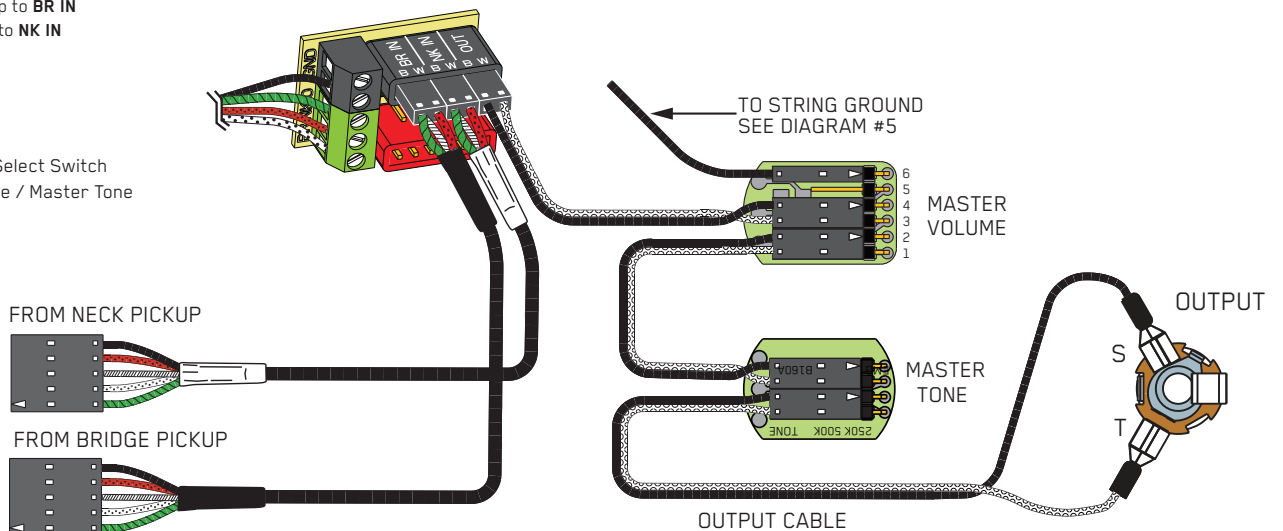

Wiring the Selection Switch

- 4) Refer to diagrams 8 and 8a, strip the insulation from the switch wires and insert them into the GREEN Terminal Block and tighten the screws with a small screwdriver.
The Bridge pickup to the **BR** Terminal
The Neck pickup to the **NK** Terminal
The Output of the switch to the **O** Terminal
If there is a ground wire coming from the switch, insert it into one of the black (**GND**) terminals on the terminal block.

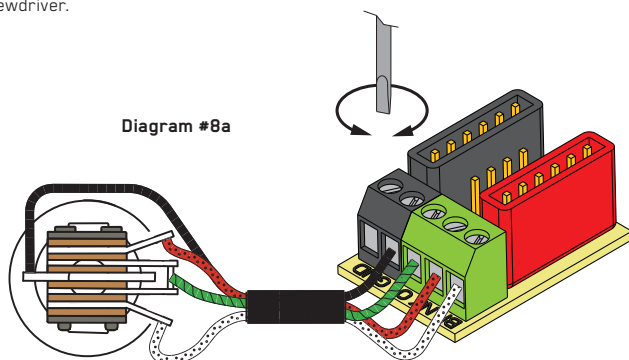
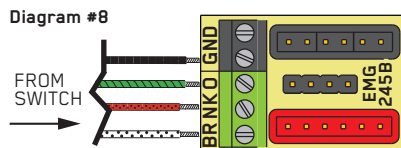

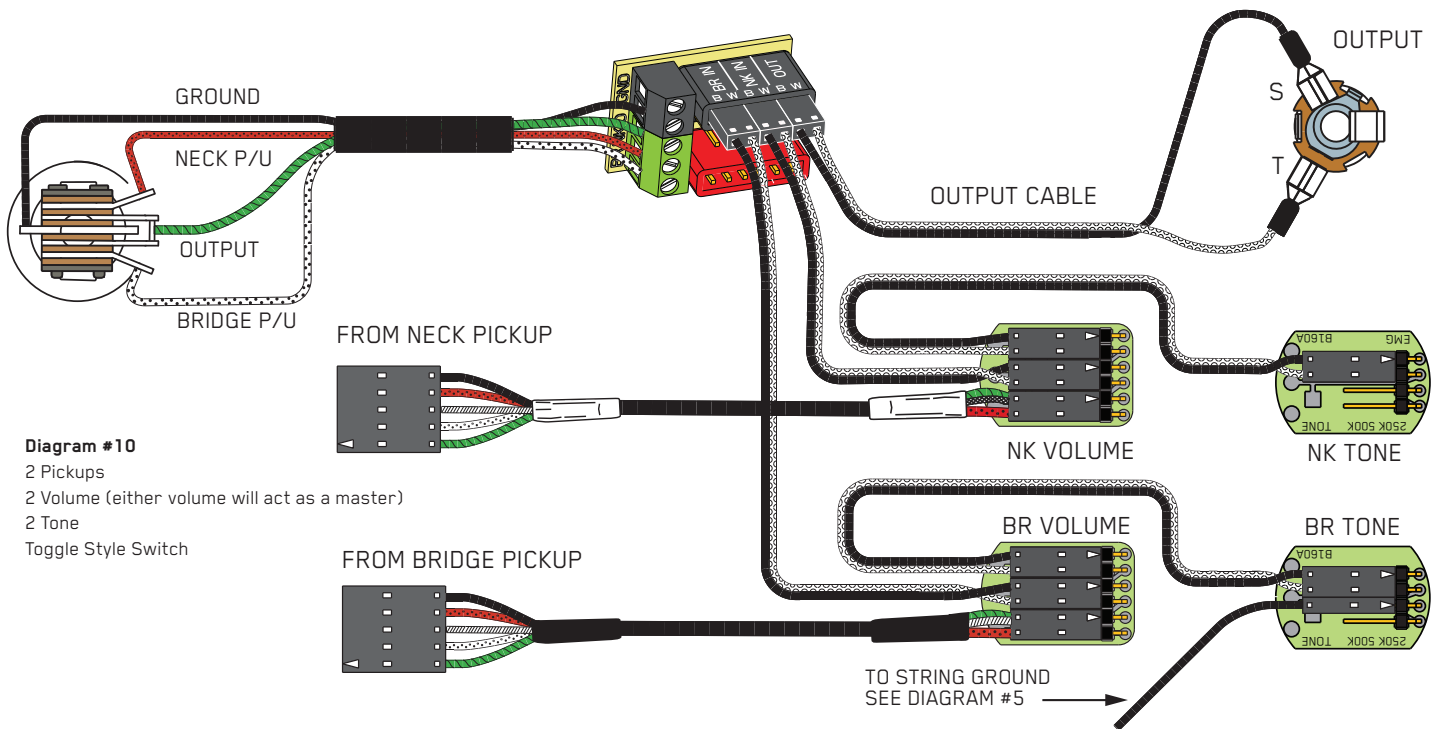
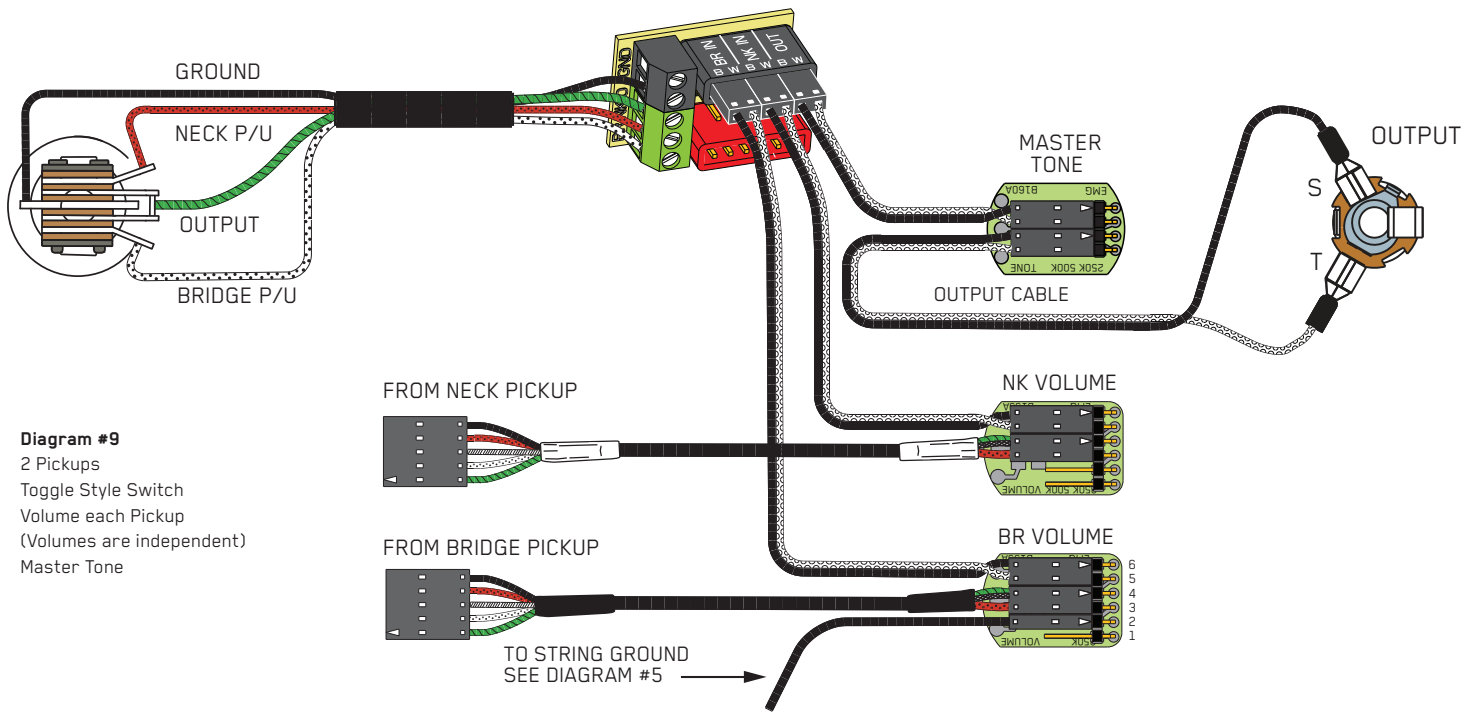

Soldering to the 151 Panel Jack:

If your instrument has a long Panel Jack like the one below you will have to solder the output cable as shown. Ground (Black) to the Sleeve Signal (White) to the Tip

