

## Read Me First!

Installation of this product is a simple procedure, but we recommend this job only if you are an experienced repair technician.

## Requirements

### Saddle slot

Minimum saddle slot length: 2.775" (70.4mm)

Maximum E to E spacing at saddle: 2.5" (63.5mm)

The Prefix preamp will only fit in guitars with a clearance of at least 2 1/4" (57.15mm) between the top and back braces, at the point where the preamp chassis swings inside the instrument.

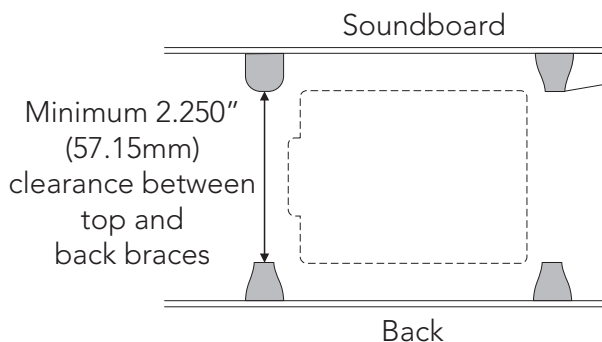

## Installation

### Preliminary

1. Widen the endpin hole to  $1\frac{15}{32}$ " (11.9mm) to accommodate the endpin jack.
2. Drill a  $\frac{3}{32}$ " hole (2.4mm) in the saddle slot for the pickup wire, no less than .100" (2.5mm) from nearest string. Install the pickup per Acoustic Matrix installation instructions.

### Cut out the preamp cavity

Please note: For instruments with solid wood sides (especially maple), we strongly recommend that you glue 2.5" (63.5mm) x .5" (12.7mm) plywood patches in the areas inside the guitar where the screw holes will be drilled. Doing so will prevent the area around the mounting holes from cracking or splintering and will strengthen the side of the instrument at the cutout.

1. Choose the flattest possible location for the preamp on the side of the instrument. The flattest and most comfortable location for the player is often at the upper bout, just above the instrument's waist and well below the shoulder. Note that the bezel has a limited ability to bend just enough to conform to the curved sides of most standard sized instruments.

Caution! When mounting the Prefix on solid wood instruments with highly curved sides (such as small bodied acoustic-electrics), exercise extreme caution when choosing the preamp location.

A highly curved mounting surface may cause the preamp to bind against the mounting bezel or in worst cases may cause the wood to crack around the preamp mounting holes.

2. Attach the enclosed cutout template at the desired location and cut out the cavity for the preamp.
3. Drill the preamp mounting holes with a #45 drill (.082" / 2.08mm).

### Output cable/endpin jack wiring

Important note: To ensure full pivot action for the preamp, remember to leave an extra 3" (76.2mm) of slack when you decide the output cable's final length.

### Solder the wire connections

1. Determine the proper length for the cable, then, if necessary, strip and tin the output wires.
2. To gain better access to the terminals on the endpin jack, gently bend back the Strain Relief/Sleeve tab before you begin to solder.

### Jack connections for the Prefix Premium Blend model

- Red wire to Tip (short terminal)
- White wire to Ring (middle terminal)
- Black wire to Switch (longest terminal)
- Shield wire to Sleeve (strain relief)

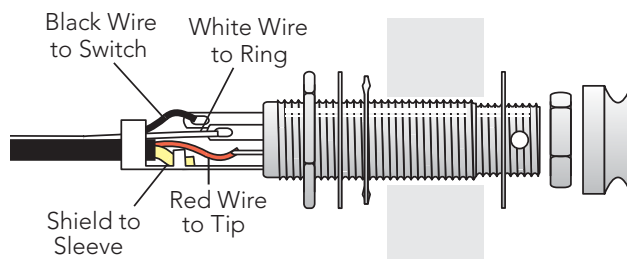

## Jack connections for Onboard Aura and Prefix Plus-T models

- Red wire to Tip (short terminal)
- Black wire to Switch (longest terminal)
- Shield wire to Sleeve (strain relief)

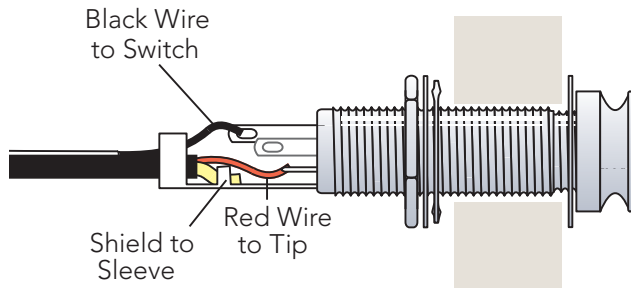

- Ring is not connected (middle terminal)

### Endpin jack

Install the endpin jack per Switchjack Installation Guide.

### Mount the preamp

1. Insert the pickup in the saddle slot.
2. Carefully pull back the "trap door" on the preamp (located next to the output cable) to expose the

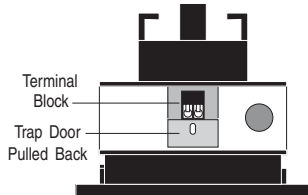

terminal block.

3. Insert the hot pickup wire (inner conductor) in the left side of the terminal block, marked "IN," the pickup ground wire (shield) in the right side of the terminal block, marked "GND," and tighten down the screws on the top of the terminal block with a  $\frac{3}{32}$ " (2.4mm) slot head screwdriver.

4. Snap closed the trap door.

5. Angle the preamp 90° from the bezel and insert it in the cut-out, then fasten the preamp bezel using the four self-tapping screws and the two plastic backing plates.

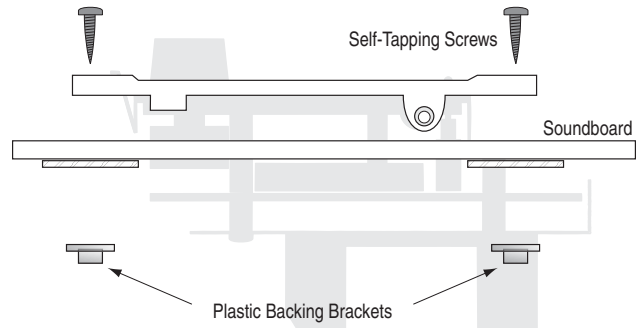

### Complete the installation

Install a 9V alkaline battery.

To keep the wires inside the guitar from rattling, secure them with the included adhesive backed clips. Attach the wire guide clips to the side of the instrument.