

Step 1: Endpin Jack Installation

Widen the endpin hole to $\frac{15}{32}$ " (11.9mm) to accommodate the endpin output jack. Refer to [Endpin Jack installation guide](#) for further details.

Step 2: Sonicore Pickup Installation

Drill a $\frac{3}{32}$ " hole (2.4mm) in the saddle slot for the pickup wire, no less than $.100$ " (2.5mm) from nearest string. Refer to [Sonicore installation guide](#) for further details.

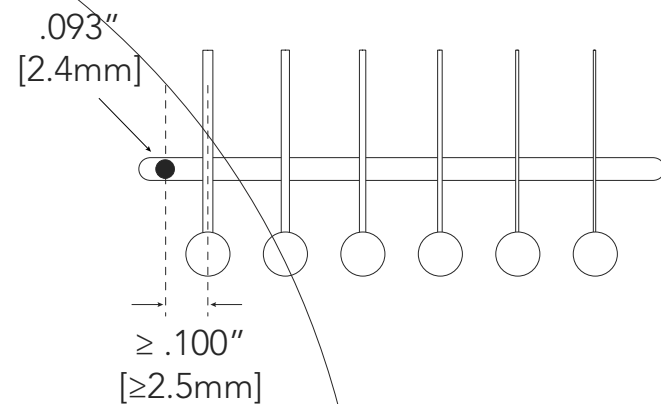

Step 3: Preamp Location

Position the preamp on the flattest convenient surface on the side of the instrument that also allows internal clearance. Cut out cavity for preamp using supplied template.

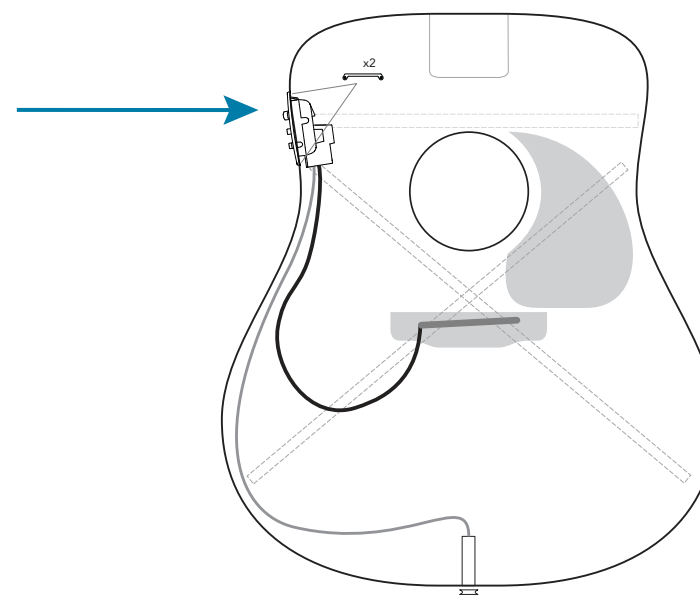

Step 4: Attach Preamp

Attach the preamp to the guitar using the supplied screws and mounting brackets.

